

Tori Seal Mechanical Seal Case Histories

Boiler Feed Pump

Plant Type:	<i>Power Generation</i>
Pump Model:	<i>Multi-Stage Ring Section Pump</i>
Service:	<i>Boiler Feed</i>
Liquid:	<i>Feed Water</i>
Pumping Temperature:	<i>85°C</i>
Flow Rate:	<i>Unknown</i>
Discharge Pressure:	<i>180 bar</i>

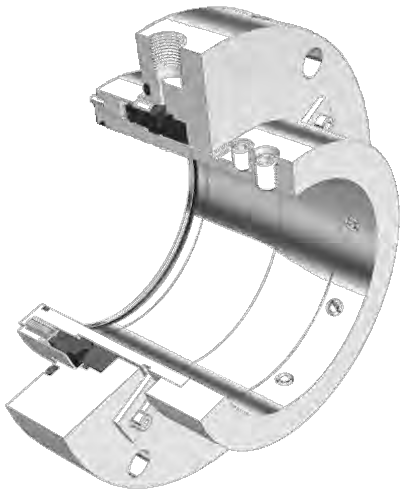
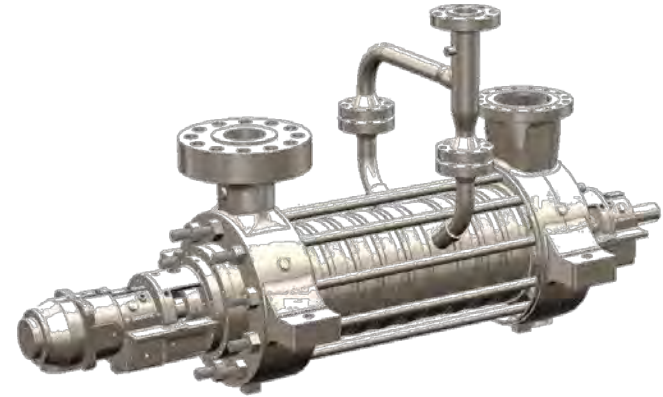

Seal Type:	<i>MB2704 Rotating Balanced Cartridge Seal</i>
Shaft Size:	<i>60mm</i>
Metallurgy:	<i>316 Stainless Steel</i>
Face Materials:	<i>Antimony Carbon/Silicon Carbide</i>
Elastomers:	<i>Viton B</i>
Seal Pressure:	<i>2 barG</i>
Pump Speed:	<i>2,982 rpm</i>
Face Velocity:	<i>13.3 m/s</i>
API Plan:	<i>02 with Seal Gland Cooling</i>



Tori Seal Mechanical Seal Case Histories

The previous seal installed was a non-cartridge component type seal. Component seals require manual setting and measuring during installation. Often, boiler feed pumps use adjusting rings to set the seals in the correct position. This can cause problems if not done correctly.

It was noted that there had been problems and premature failures with the previous seals. These failures were said to be the result of seal installation and setting errors by a previous maintenance service provider.

The local Torishima Service Solutions branch received these boiler feed pumps for repair and overhaul. During this phase it was decided to convert the seal type from non-cartridge to cartridge type. This gave the added benefit of quick and easy installation due to the cartridge being factory preset and preassembled. There were no irreversible modifications required to the pump and the seal gland cooling system of previous seal was implemented on the new Tori Seal cartridge design to ensure the cooling efficiency was equal or better.

In addition, Tori Seal was able offer a more cost effective alternative to the seal repair cost quoted by the previous seal manufacturer. The new cost of the previous seal would have further exceeded even this cost.

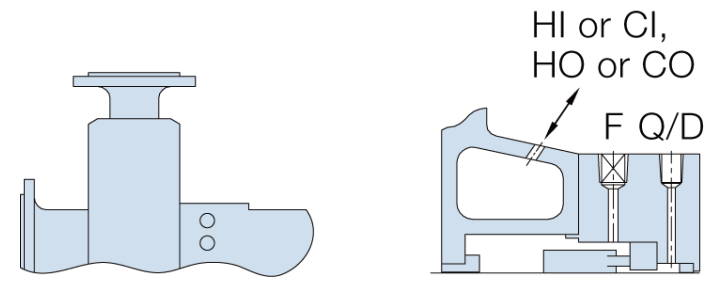

Plan 02 Dead End with Seal Gland Cooling

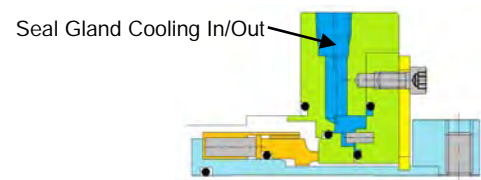

Preset and Preassembled therefore no more manual setting required. Quick and easy installation.

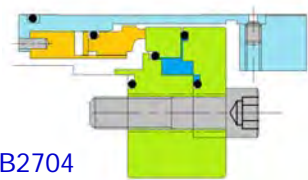

Tori Seal MB2704



Tori Seal MB2704



TORI SEAL

Over Half a Century of Sealing Reliability

